

2012

Steelworks Supervision Guide



ACES/IES

For Qualified Site

Supervisors (QSS)

1st Edition Sep 2012

Steelworks Supervision Guide

For Qualified
Site Supervisors (QSS)

Published by:

**ASSOCIATION OF CONSULTING ENGINEERS
SINGAPORE**

INSTITUTION OF ENGINEERS, SINGAPORE



Steelworks Supervision Guide

For REs and RTOs

Table of contents

Section		Page
1.1	Scope	8
1.2	Quality of Structural Steelworks	8
1.3	Copies of Orders	11
1.4	Marking of Steel	11
1.5	Factory Production Control Certificate and Manufacturer Test Certificate	13
1.6	Storage, Handling and Transportation	16
1.7	Shop Drawing and Quality Plans	17
1.8	Fabrication	17
1.9	Assembly and Erection	20
1.10	Welding	38
1.11	Bolting	53
1.12	Riveting	55
1.13	Inspection	55
1.14	Inspection and Testing Agency (ITA)	55
1.15	Load Testing	55
1.16	Protection against Corrosion	56
1.17	Surface Preparation	57
1.18	Fire Protection	61
App	Guide on accuracy of fabrication	64
App	Guide on accuracy of erection	70

ACKNOWLEDGEMENTS

1. Joint Accreditation Committee (JAC)
2. Building and Construction Authority (BCA)
3. Association of Consulting Engineers Singapore (ACES)
4. Institution of Engineers Singapore (IES)

The resources made available by the above organisations are gratefully acknowledged.

The retail price for this book is \$20.

PREFACE

This guide shall serve only as a quick guide to facilitate construction supervision for Resident Engineers (REs) and Resident Technical Officers (RTOs).

REs and RTOs MUST still refer to approved drawings, building specifications, codes, other relevant documents and relevant authorities' requirements for the exact execution of the works.

References are made to BC1: 2012 Design guide on use of alternative steel materials published by BCA.

Technical Editor: A/Prof Er. Dr. Chiew Sing-Ping
Nanyang Technological University

Foreword by President, IES

Dear Resident Engineer / Resident Technical Officer,

The supervisory role that you play at the worksite is of paramount importance when it comes to safety and in ensuring the quality of the work. Most accidents at the worksite can be prevented if the site supervisors are more careful or alert to the process and procedures applied. Neglect and non-conformance to standards and guidelines were the two main factors that caused accidents.

It is with this in mind that this Steelwork Supervision Guide for Qualified Site Supervisors is launched to provide guidance on the supervision of structural steel works at construction site in the areas of material, fabrication, erection, testing, corrosion, fire protection, as well as proper documentation, which is also an important area when handling structural steelworks at worksite, as the documentation will also ensure that the job has been done correctly.

I hope that all Res / RTOs will make full use of the guidelines in this guidebook and apply them in the course of their work so that the workplace could be made safer. I would like to thank A/Prof Er. Dr Chiew Sing-Ping of National Technological University for editing this guidebook so as to provide easy understanding of the areas that site supervisors would need to pay attention to when supervising structural steel works at worksite.



Er. Ho Siong Hin

President, The Institution of Engineers, Singapore

Foreword by President, ACES

The importance of our QSS as part of our consultancy work cannot be underestimated in the Built Environment. We depend heavily on the professionalism of our QSS on the ground to help ensure that our designs are followed through on sites and the products delivered safely and according to specifications to our ultimate clients.

In this regard I must commend the JAC for the superb work that they have contributed to these two sets of guide books to assist our QSS in their daily work.

This is part of the journey towards even more professionalism in our work and I look forward to more such initiatives in the Built Environment.

Thank You.



Er. Koh Boon Liang

President, Association of Consulting Engineers Singapore

Process Flow Chart for Structural Steelwork

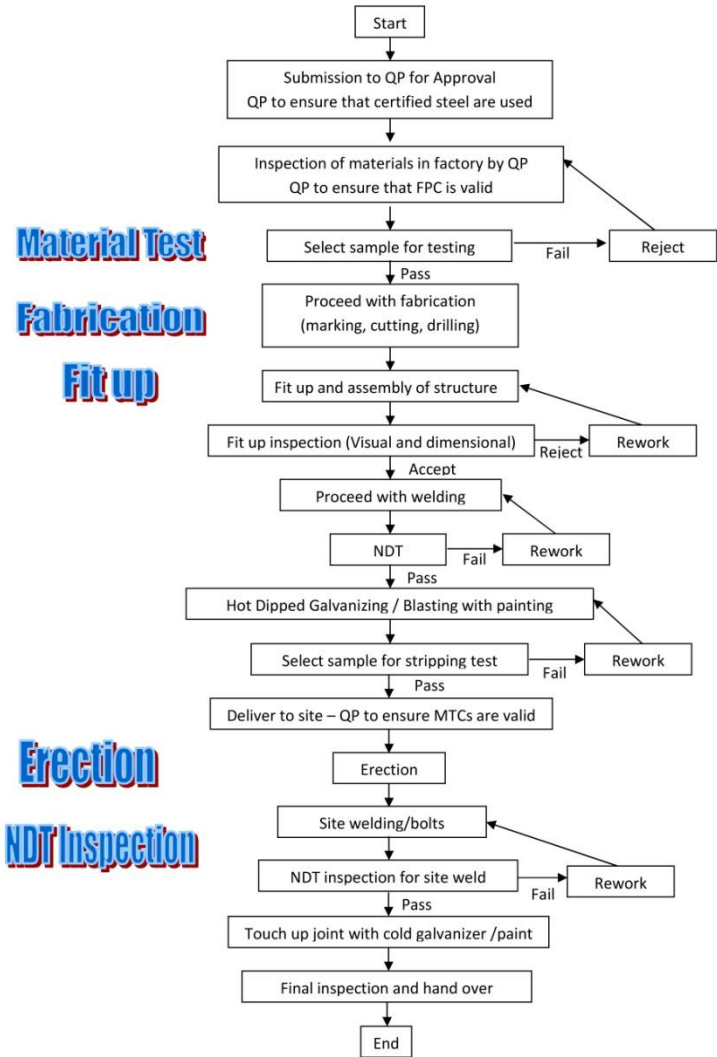

1.1 Scope

This guide provides guidance on the supervision of structural steelworks in the areas of material, fabrication, erection, testing, corrosion and fire protection.

Inspection of materials in factory:

- a. Must be new materials with manufacturer test certificate (MTC)
- b. Materials must be produced from manufacturers with valid factory production control (FPC) certificate
- c. Countercheck the tag/printing on raw material to be tally with manufacturer certificate with heat numbers submitted
- d. Correct material (shall comply with latest codes)
- e. Correct size (dimensional inspection)
- f. Check physical defects for any heavy rusting, pitting, warping and bending

1.2 Quality of structural steelworks

- Prior to commencement of works, the builder shall submit to the QP for approval, a QA/QC manual which shall include, at the very least, the following:
 - a. Structural steel fabricator accredited to SSSS
 - b. Site and factory organisation chart
 - c. Material handling process and control
 - d. Fabrication process
 - e. Erection process
 - f. Repair of defects process
 - g. Inspection and testing plan
 - h. List of welding procedure specifications (WPS)
 - i. List of qualified welders

- All materials shall be certified steel which comply with the requirements of BC1: 2012. To qualify for Class 1 steel materials, certified steel must be produced from manufacturers with valid FPC certificates.
- Certified steel (BS EN, ASTM, AS/NZS, JIS and GB) without valid FPC certificate can only qualify as Class 2 steel materials in accordance with BC1.
- Steel other than BS EN, ASTM, AS/NZS, JIS and GB can only be used if material tests are carried out in accordance to Appendix B of BC1 to demonstrate compliance with material performance requirements. Such non-certified steel can only be classified as Class 2.
- Steels which do not have valid FPC and/or MTC, or failed the material testing requirements shall be classified as Class 3 and can only be used only for non-structural applications.
- Substitution of steel sections with equivalent sections shall be approved by the QP prior to actual fabrication.

1.3 Copies of Orders

Two copies of orders and suborders placed by the Builder shall be forwarded to QP.

1.4 Marking of Steel

- Steels shall be marked complying with requirements of standards designated in 1.2.
- Where steels of different grades are used, they shall, with the exception of Grade S275, have additional markings as specified.

Material Testing Schedule

SAMPLE

BSS S73
73-8 of 73-83

73.1 TESTING OF MATERIAL (CONT'D)

SCHEDULE OF MATERIAL TESTS

S/N	TYPE OF MATERIAL TO BE TESTED	TYPE OF TEST TO BE CARRIED OUT	FREQUENCY OF TEST FOR EACH TYPE OF TEST	NO. OF SAMPLES PER TEST
24	Weld (for steel structure)	Either one or a combination of : a) Radiographic b) Ultrasonic c) Penetration d) Magnetic particle))))) 1 test per 10 joints.))))) 1 joint per test.
25	Steel section and plates	a) Yield b) Tensile c) Notch toughness d) Ductility e) Weldability))))) 1 test per source.))))) 1 sample per test.
26	Galvanised steel section	Stripping	1 test per source.	2 samples per test.
27	Anchor bolt for sun-breaker	Pull-out	5 tests per building block.	1 bolt per test.

Material Test report

Results:

Table 3 : Chemical Composition

Sample Reference	S45 150 X 150 X 8,0 mm thick	RHS 200 X 100 X 6,3 mm thick	RHS 250 X 100 X 6,3 mm thick	BS EN 10210-1 : 1994 Grade S355J0+ Requirements
Element				
Carbon, C (%)	0.12	0.12	0.13	Max. 0.25
Silicon, Si (%)	0.16	0.16	0.22	Max. 0.30
Manganese, Mn (%)	1.37	1.54	1.34	Max. 1.70
Phosphorous, P (%)	0.020	0.022	0.012	Max. 0.04
Sulphur, S (%)	0.008	<0.007	0.010	Max. 0.045
Carbon Equivalent Value, CEV (%)	0.35	0.37	0.39	Max. 0.45

Remark : < denotes less than the minimum value

Compare the results with requirements

Material Tag





1.5 Factory Production Control Certificate and Manufacturer Test Certificate

1.5.1 Factory Production Control (FPC) Certificate

- The manufacturers shall have a FPC system attested by an independent third-party certification agency acceptable to or recognised by BCA.
- Validated copy of the valid FPC certificate shall be submitted to the QP during the material procurement stage for approval.

1.5.2 Manufacturer Test Certificate

- The Builder shall supply the manufacturer test certificate in accordance with the standard designated in 1.2.
- The manufacturer certificate shall be endorsed and certified by the supplier. Notwithstanding this, test pieces shall (as and when required) be prepared and tested in accordance with the requirements stated in BC1: 2012.

1 Factory Production Control Certificate to RC1.

In compliance with the Factory Production Control requirements of the Building and Construction Authority, Singapore.

This is to certify that the Factory Production Control system of:

2 Name of the manufacturer

in the factory located at:

3 Address of factory

has been assessed under the Factory Production Control requirements of **RC1** and conforms to its requirements for the production of

- 4** { *List of product standards and, if appropriate:-*
- *standard for manufacturing tolerances (see Appendix A of RC1.*
 - *additional provisions to which the product conforms*
 - *particular conditions applicable to the use of the product (addendum sheet if necessary)*

5 Conditions and period of validity, where applicable

This certificate is only valid when:

- 6** {
- Certificate no.: *BC1-1234-56789*
 - First issue date: *21 February 2008*
 - Current issue date: *21 February 2008*
 - Expiry date: *20 February 2011*

8 { 
Name and address
of the certification
agency

7 { *Authorised
signatory*
.....
Name and position
on behalf of
name of the certification agency

1.7 Shop Drawing and Quality Plans

- The Builder shall prepare his shop drawings, quality plans and calculations showing the grade of steel, sizes, dimensions and details required for the purpose of fabrication and erection.
- Weld symbols shall be stated clearly.
- Prior to fabrication, two copies of the shop drawings and quality plans shall be submitted to QP for approval.

1.8 Fabrication

1.8.1 General

- Fabrication shall in general be carried out in accordance with BS 5950-2 and BS 5950-7 and for bridges BS 5400-3 and BS 5400-6.
- All steelworks shall be fabricated from new sections and in such a manner that they are not bent, twisted or damaged.
- Third party check is required for overseas fabrication. The Builder shall ensure all steel works are checked in accordance with Checklist 1.
- The steel fabricator employed shall be accredited under the Singapore Structural Steel Society's (SSSS) Accreditation Scheme and in the category appropriate for the project.

1.8.2 Templates

- Full-sized templates necessary for fabrication when required shall be forwarded to the QP by the Builder.

1.8.3 Cutting

- Cutting of steelworks may be by shearing, cropping, sawing or machine flame cutting. All cut edges shall be dressed to a neat workmanlike finish, and shall be free from distortions.

Cutting

- Check all dimensions in the drawing before fabrication.
- Cutting of material according to cutting plans.
- Cutting of structural steel shall be by milling, saw cutting or mechanically guided flame cutting.
- Cut surface shall be sound in terms of straightness and smoothness without excessive notches or slag-attachment. All cutting edges must be grind to smooth before assembly.

Drilling

- Bolt holes shall be drilled at right angle to the material surface. Hole enlargement by flame cutting is not allowed. All burrs resulting from drilling shall be removed.

Marking

- Material for a project must be marked from other project materials.
- Each item that is fabricated shall have a tag or stamp on it for identification. Heat number is to be transferred to cut components.
- These identification marks will facilitate traceability from the beginning of fabrication through transportation, erection until completion.



Cutting of steel plate by using mechanical guided flame cutter.



Drilling of bolt hole on I-section.



Sample of steel plate cut by flame cutter.



Edge grinding work for welding.

Table 33 — Standard dimensions of holes for non-preloaded bolts

Nominal diameter of bolt mm	Standard clearance hole	Oversize hole ^a	Short slotted hole		Long slotted hole ^b		Kidney-shaped slot	
	Diameter mm	Diameter mm	Width mm	Length mm	Width mm	Length mm	Width mm	Length mm
12	13	16	13	16	13	42	13	36
16	18	20	18	22	18	56	18	48
20	22	25	22	26	22	70	22	60
22	24	27	24	28	24	77	24	66
24	26	30	26	32	26	84	26	72
≥ 27	$d + 3$	$d + 8$	$d + 3$	$d + 10$	$d + 3$	$3.5d$	$d + 3$	$3.0d$

NOTE d is the nominal diameter of the bolt (in mm).

^a Larger diameter holes may be used for holding-down bolts.

^b Longer slots may be used for expansion joints.

Table 36 — Standard dimensions of holes for preloaded bolts

Nominal diameter of bolt mm	Standard clearance hole	Oversize hole	Short slotted hole		Long slotted hole	
	Diameter mm	Diameter mm	Width mm	Length mm	Width mm	Length mm
16	18	20	18	22	18	40
20	22	25	22	26	22	50
22	24	27	24	28	24	55
24	26	30	26	32	26	60
≥ 27	$d + 3$	$d + 8$	$d + 3$	$d + 10$	$d + 3$	2.5d



1.8.4 Tolerance

- Members and component of rolled and built up sections shall be checked for tolerances in accordance with Tables 7 and 8 of BS 5400-6.

1.8.5 Protection of Hollow Section

- Unless special protection is provided for by other means, the interior of any hollow members, whether a structural hollow section or a fabricated member, shall be sealed up to prevent the ingress of water.

1.9 Assembly and Erection

- Assembly and erection of structural steelwork shall be carried out in accordance with BS 5950-2 and BS 5950-7 and for bridges BS 5400-3 and BS 5400-6.



- Structural steel work shall be fabricated and assembled in the workshop to the greatest extent possible.

Fit up inspection

- Check the assembly of structure by using approved shop drawing and their material identification.
- Ensure materials in good condition. e.g. not dented, no warp, not twisted, straight alignment.
- Members to be welded must be brought into correct alignment and held in position by suitable devices or tack welds.
- Tack welds, which are incorporated into final weld shall subject to the same welding procedure requirements as the final weld.
- If required, cambering shall be provided in accordance with the consultant's design and formed by mechanical means.
- Visually inspect the surface of joints to be welded is free from scale, rust, grease, dampness and other foreign materials and its bevel and root gap shall be within requirements in accordance to the qualified WPS. Welding joints constructed must follow approved drawings.
- Check the dimensions of the assembled structure like overall length, overall height, spacing between members and angle.

Bevel and root gap

Fillet Weld

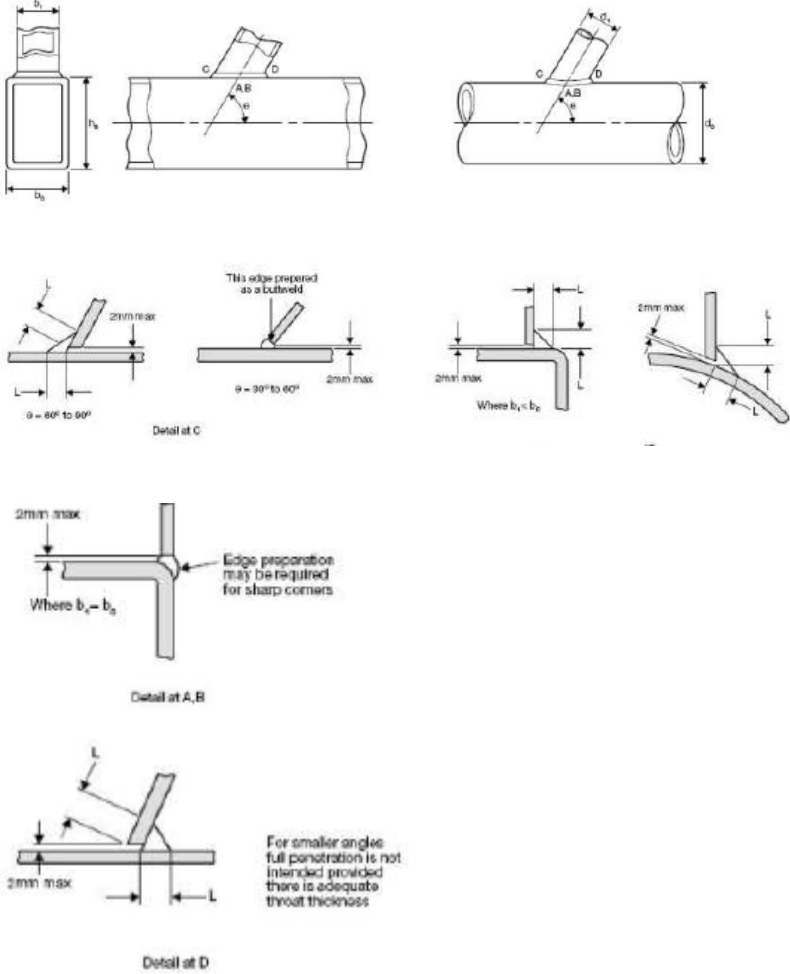

Butt Weld

Square butt weld - without backing

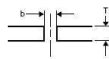
Weld detail	Thickness T	Gap b
	mm ≤ 4	mm = T

Square butt weld - with backing

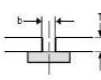
Weld detail	Thickness T	Gap b	
		min.	max.
	mm 3-8	mm 6	mm 8

Single V - with backing

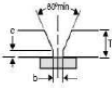
Weld detail	Thickness T	Gap b		Thickness of root face c	
		min.	max.	min.	max.
	mm Up to 20	mm 6	mm 8	mm 1	mm 2.5

Single V - with or without backing

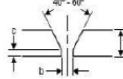
Weld detail	Thickness T	Gap b		Thickness of root face c	
		min.	max.	min.	max.
	mm Up to 10	mm -	mm 4	mm -	mm 2

Single bevel - without backing

Weld detail	Thickness T	Gap b		Thickness of root face c	
		min.	max.	min.	max.
	mm Up to 20*	mm 2	mm 4	mm 1	mm 2

Single bevel - with backing

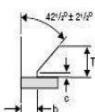
Weld detail	Thickness T	Gap b		Thickness of root face c	
		min.	max.	min.	max.
	mm Up to 20	mm 5	mm 8	mm 1	mm 3

1.9.2 Method of Erection

- The Builder shall submit to QP prior to the erection, the method and sequence of erection, temporary works, details of plant and equipment and their inspection certificates and all other relevant drawings and calculations duly endorsed by his own PE, for approval.
- The manufacturer test certificate and factory production control certificate shall be checked prior to erection. Replacement shall not be allowed without permission. The Builder shall ensure that the structure is not subject to excessive deflections and stresses during erection.

1.9.3 Trial Assembly of Erection

- If required the Builder shall carry out trial assembly and erection of the steel structure at the fabrication yard or other convenient place.

1.9.4 Accuracy in the Structure

- Unless otherwise specified, all structural steelworks shall be fabricated, assembled and erected to the accuracy in accordance with BS 5606.

Erection sequence

Generally the erection shall comply with the following:-

- Erection Method Statement must be approved by QP and provided during erection.
- The Method Statement shall include organization chart, lifting and stability, erection sequence and stability of structure, detail method of installation and risk assessment.
- Crane setting out, type and hoisting capacity must be adequate.

- Temporary brace / props must be adequately provided for safety & stability.
- Check structural steel alignment, level, plumb and correctness. Steel packing and wedges shall be used for alignment & levelling work.
- All tack welds shall be grounded smooth and holes shall be filled with weld metal then smoothed by grinding.
- Grouting work under stanchion bearing plates shall be done when sufficient portion of the structure have been plumbed and aligned. Use only approved type of high strength non-shrink grout in accordance with manufacturer's instructions.
- All calibration certificates for hydraulic jacks must be submitted. (If applicable).
- All damaged galvanized or painted surfaces to be touched up with approved repair procedure.
- Tolerance for erection to be referred to QP, quality assurance plan and comply with BS5950 part 2.
- Contractor to submit report of level check, verticality, alignment check to QP if requested.

Site welding/bolts installation

Site welding procedures are similar to those at the workshop:

- Ensure correct type, grade, quantity & size of bolts installed on site.
- Bolts tightened to correct torque according to manufacturer's recommendation.
- Minimum 1.5 thread length beyond nut after tightening.
- Tilted bolts not acceptable.
- Drilling through hollow section not allowed.
- All bolts shall be provided with spring washer.
- Contractor to submit bolts tightening inspection report.

SSSS Steel fabricator Accreditation Scheme - HR Criteria

Human Resource Criteria	Category			
	S1	S2	S3	S4
<u>Professional:</u>				
PE	1	0	0	0
Engineer	3	2	1	0
Supervisory	3	2	1	1
<u>Skilled Technical</u>				
Welder (from 3G)	10	5	3	1
Fitter	5	3	2	1

1.9.5. Erection- General

- Whilst steelwork erection may be regarded as the final stage of fabrication, it differs from the latter in two principal ways:
 - firstly, there is the added dimension of height and the time occupied by vertical movement of materials, equipment and labour;
 - secondly, the fact that work has to be carried out in the open means that progress may be hampered by adverse weather.
- Clearly the significance of the various issues will vary according to the type of building and any limitations which the site and its environment may impose. Even when structures possess marked similarities, different erection methods and procedures may need to be adopted. For this reason, only the broad principles concerning erection can be stated.

1.9.5.1 Site Planning

- Erection of structural steelwork has to be closely integrated with other major trades such as flooring, cladding and services. Operations on site where there may be competition for limited resources are potentially difficult to control. A far-sighted strategy has to be developed and maintained.
- Key objectives and, most importantly, starting and finishing dates must be clearly established and progress reviewed on a regular basis. Failure to meet commitments can result in substantial cost penalties. Further complications may easily arise which are totally disproportionate to the cause.

1.9.5.2 Site Organisation

- The maximum size and weight of the various steel members which can be delivered may be restricted on a site with limited and restricted access.
- Narrow streets in a busy town centre may cause difficulties with space to manoeuvre. Waiting time to off-load may also be restricted to specific periods. Matters of this kind must be investigated well in advance and decisions made accordingly.
- Within site, movement may often be hampered by a variety of obstructions such as scaffolding, shoring, pile caps, excavation, and so on. Service roads and off-loading areas need to be hard cored and adequately drained to support heavy vehicles during the severest weather conditions.
- The steelwork has to be erected in the general sequence determined by the construction programme. Each consignment of steel has to be strictly regulated to this timetable. Whilst in some instances, a few key components can be lifted directly from the vehicle into position, most of

the material will need to be off-loaded and stacked temporarily until needed.

- The area of the site allocated for this purpose has to be orderly and well managed, particularly where space is limited. To compensate for minor interruptions in delivery, for example due to traffic delays, a small buffer stock is usually held in reserve.
- Space is also required for laying material out and for assembly of frames or girders prior to hoisting into position.

1.9.5.3 Setting Out

- Before commencement of erection, the plan position and level of the column bases should be verified by the erection contractor. This needs to be carried out as soon as possible to ensure that any errors can be corrected in good time or, at least, alternative measures approved and introduced.
- Checks should include not only the centres of the foundation bolts relative to the reference grid lines, but also the projection of the bolts above the base level.
- To compensate for minor discrepancies, a limited amount of deviation of the column from its true vertical and horizontal position is provided for by the grout space under the base plate and by leaving a movement pocket around each bolt during pouring of the concrete. Normally this will allow latitude of about $\pm 25\text{mm}$ in any direction.

1.9.5.4 Operations

- Steel erection may appear to be a series of distinct operations when in reality they overlap and merge. Nevertheless, each complete stage of the work has to follow a methodical routine which consists of:
 - Hoisting
 - Temporary Connections
 - Plumbing, lining and levelling
 - Permanent connections
- Because minor dimensional inaccuracies can accumulate during fabrication and setting out, it would be impractical to complete the entire structure before compensating for these by adjustment.
- The work is therefore sub-divided into a number of phases which may be controlled by shape or simply by an appropriate number of bays or storeys. For stability, each phase relies upon some form of restraint to create a local box effect. This effect may be achieved in various ways, such as employment of temporary or permanent diagonal bracing.

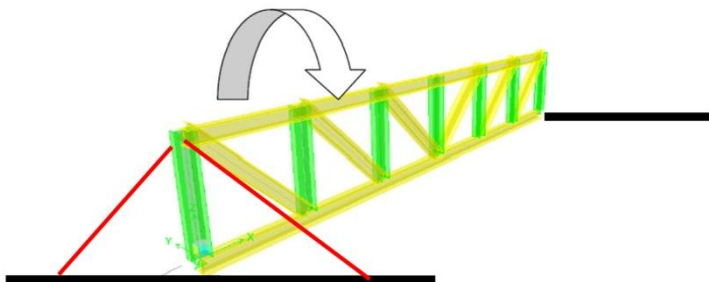

Temporary bracing

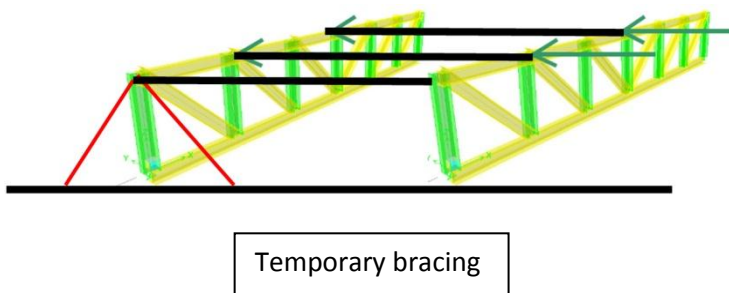

- Initially, end connections and base anchorages are only secured temporarily. After completion of plumbing, lining and levelling, all connections are then made permanent by tightening up all nuts or inserting any bolts initially omitted to assist adjustment. This process allows substantial areas to be released quickly for grouting and following trades are able to proceed much earlier than would otherwise be possible.

1.9.5.5 Single-Storey Buildings

- Under normal circumstances, single-storey buildings are quickly and easily erected. A high proportion of industrial buildings are rigid jointed. It is common practice to bolt, assemble or weld these joints on the ground and then lift the complete frame upright using a mobile crane.
- Lattice girders and trusses are also erected in a similar manner but temporary stiffening may be required to prevent lateral buckling. Care should also be taken, by provision of lifting eyes or similar at specific positions, to ensure that slender members are not subjected to undue compressive stresses.
- Ideally, erection should commence at an end which is permanently braced. When this is not possible, temporary

bracings should be provided at regular intervals as a safeguard against collapse or deformation (Figure 7).

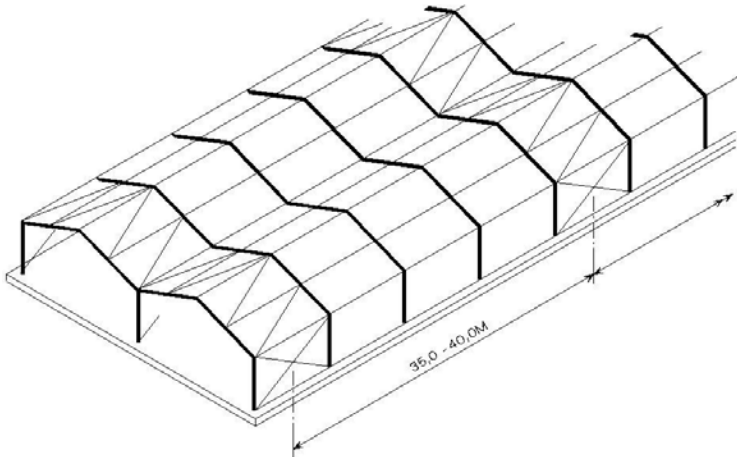

Figure 7 Single storey building

- Space frames are designed to span in two directions. Due to the number of connections required, it is much more economical to assemble the modules at ground level where the joints are readily accessible and then hoist the complete framework. Two or possibly four cranes may be needed depending on the size of the building. Meticulous coordination is essential.

1.9.5.6 Multi-storey Buildings

- Multi-storey buildings are erected storey by storey enabling the lower floors to be completed earlier, offering access, overhead safety and weather protection.
- Depending upon the site, a single tower crane may be the sole lifting facility. In this case, use of the crane has to be

shared among a number of sub-contractors, thereby limiting available "hook" time for any given trade.

- Since the position of a tower crane is fixed (Figure 8), it is completely independent of any obstructions, such as basements or ground slabs, which could deny access to a mobile crane. This independence allows useful freedom in overall planning.
- However, the fixed location also means a fixed arc of lifting capacity where the load will be minimum at the greatest reach. As a result the steelwork may have to be provided with site splices simply to keep the weight of the components within such limits.

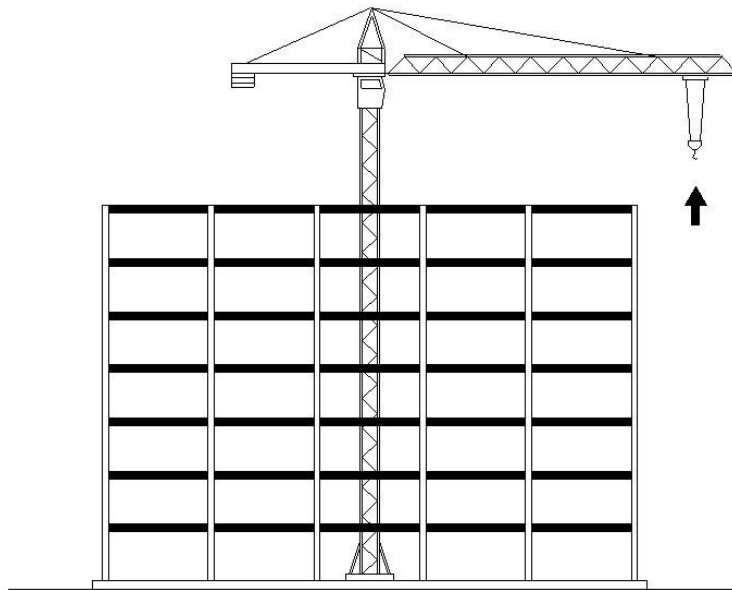

Figure 8 Multi-storey building erected by tower crane

- One of the major virtues of a mobile crane (Figure 9) is its flexibility and independence which enables it to keep moving with the flow of the work. These cranes are generally fitted with telescopic jibs which allow them to become operational very quickly. The vehicles are stabilised during lifting by extended outriggers equipped with levelling jacks.

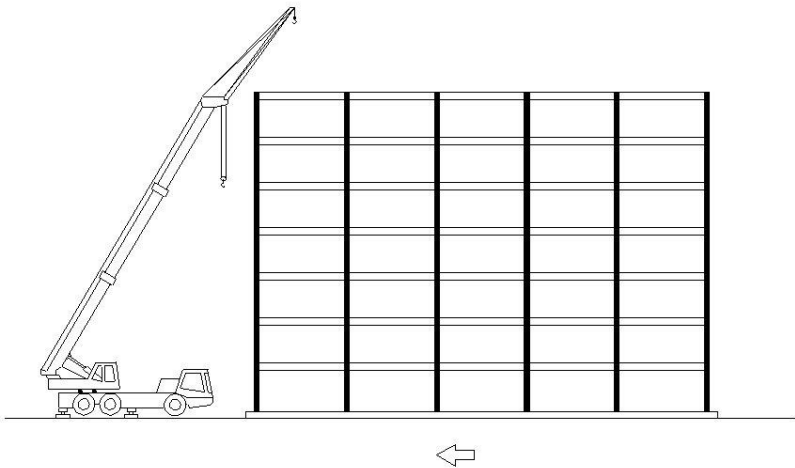

Figure 9 Multi-storey building erected by mobile crane

- Whilst permanent stability in the completed building may be introduced, in a number of ways, including braced bays, rigid joints and stiff service cores (Figure 10) and via diaphragm action of the floors, stability must also be ensured throughout the entire construction programme.
- It may therefore be necessary to install temporary bracings solely for this purpose, which must not be removed until the permanent system has been provided and has become effective.

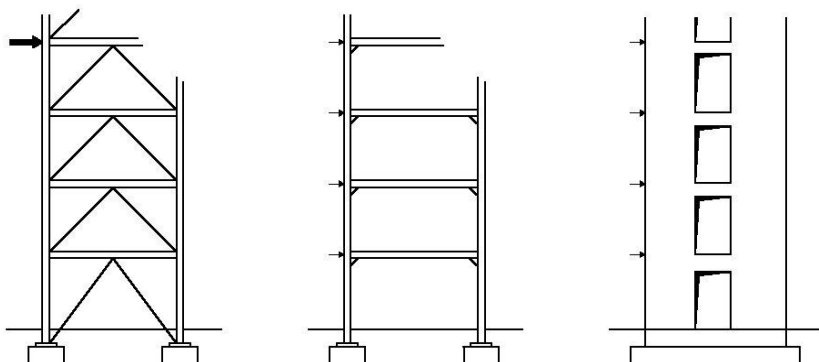

Figure 10 Bracing systems

1.9.5.7 Timing

- The rate of steelwork erection is governed by a wide range of factors some of which are beyond the influence of the design engineer. The factors which he can control include:
 - type of end connections.
 - extent / type of bolting or welding.
 - number of separate pieces.
- Simple connections for shear force are straightforward and employ Grade 4.6 or 8.8 bolts. The bolt diameter should be selected with a degree of care. For example, whilst a single M30 bolt has more than twice the shear capacity of two M20's, the effort required to tighten an M30 bolt is some 3½ times greater. An M20 bolt can be tightened without difficulty using ordinary hand tools, a considerable advantage when working at height.

- Joints which are required to transmit bending moments are inherently more robust and may require stiffening ribs and haunches; if this is the case careful attention is required to ensure access for the bolts. For such applications pre-tensioned bolts are often used. They are normally tightened to a minimum torque using a power operated wrench.
- Compared to bolting, the site welding of joints is time-consuming and expensive for conventional structures. There may be occasions, however, when site welding is the only realistic way to form a joint, as, for example, in alterations or remedial work. In this case, joint preparation, fitting, inspection and the provision of purpose made enclosures (for access and weather protection) are additional cost factors that must be taken into account.
- As a rough guide, about 50% of erection man hours are occupied with lining, levelling, plumbing and final bolting and the remainder of the time is spent hoisting members into position. However, in suitable cases, beam and column elements may be pre-assembled at ground level and lifted directly on to their foundations.

1.9.5.8 Safety

- The erection of a building framework is potentially hazardous. Many serious and fatal accidents occur each year on construction sites and most of these are caused by falling from, or whilst gaining access to, heights; handling, lifting and moving materials, however, are also hazardous.
- Risks can be minimised considerably by measures such as adequate provision for stability throughout construction, accessibility of splices and connections, guard rails and attachments for safety harnesses and so on.

- In addition, safety need not be compromised on grounds of cost. For example, it will prove cheaper to assemble frames at ground level (Figure 11) rather than bolt them together in mid-air. Metal decked floor systems are not only economical but offer rapid access for all trades whilst providing overhead protection. Safer access is also promoted by the immediate provision of steel stair flights at each floor level as steelwork erection proceeds.

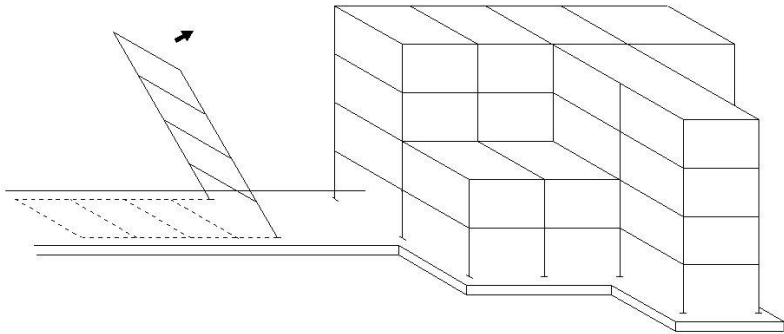

Figure 11 Erection of assembled frames

- Current and future legislation may place greater responsibilities upon the design engineer because of the influence of design and details on the method and sequence of erection.

1.10 Welding

1.10.1 General

- All metal arc welding shall be done in accordance with BS EN 1011-1 and BS EN 1011-2. Spot welding of cold-formed steel sections shall conform to the requirements of BS 1140.
- Generally, preheating is not required and welding can take place at room temperature. Preheating may be desirable or necessary when joining thick parent plates or large members, or when applying small welds with little heat on large material thickness.
- The final decision about preheating shall be made by the fabricator taking into consideration shop or site conditions, material quality, design configuration, etc.
- The primary concerns of the weld inspector are:
 - (a) The welds produced are fully in accordance with the sizes and shapes denoted on the shop drawings;
 - (b) The weld preparations are correct before welding commences; and
 - (c) Any deviation from the correct shape and fit-up is reported so that any necessary change in the established welding procedures may be determined.

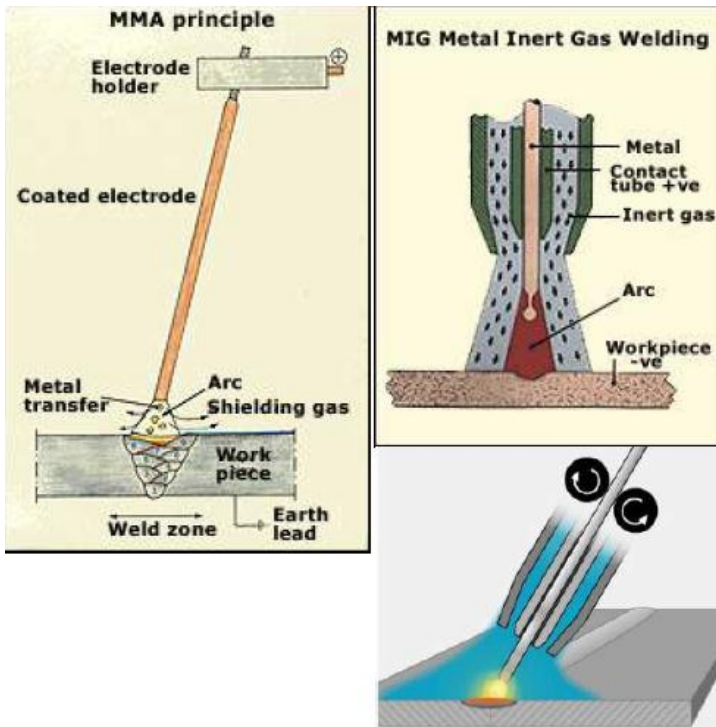

Welding Process

- Heat source is an electric arc established between the parts to be welded and a metallic electrode. The electrical energy, converted to heat, generates an arc temperature of some 7,000°C (10,000°F), causing the metals to melt and join.
- Arc processes include Manual Metal Arc, Gas-Shielded Metal Arc, Gas-Shielded Tungsten Arc and Submerged Arc Welding. Most commonly used method on sit is manual metal arc welding (MMAW)/ shielded metal arc welding (SMAW) and metal inert gas welding (MIG)/ gas shielded metal arc welding (GMAW).



Manual Metal Arc Welding (MMAW)/ Shielded Metal Arc Welding (SMAW)

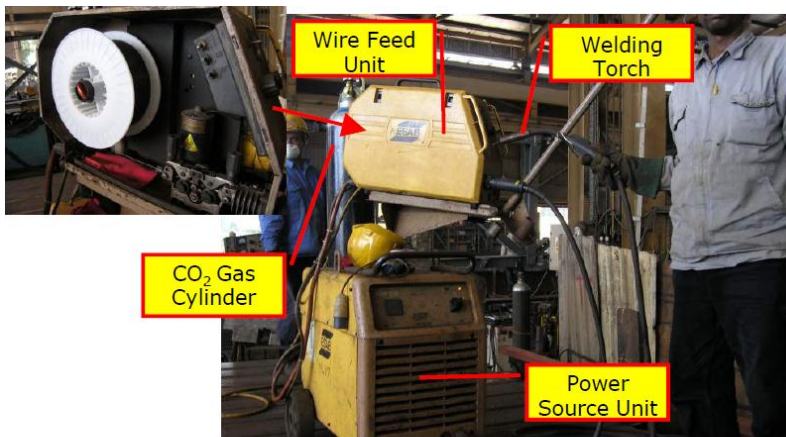

Metal Inert Gas Welding (MIG)/ Gas Shielded Metal Arc Welding (GMAW).

Welding Process	Classification	Manufacturer	Example of Product
MMAW/SMAW	SFA/AWS A5.1; EN 499	ESAB	OK 53.04
MMAW/SMAW	SFA/AWS A5.1; EN 499	KOBELCO	LB-52/LB52U
MIG/GMAW	SFA/AWS A5.20	ESAB	OK Autrod 15.41
MIG/GMAW	SFA/AWS A5.20	KISWEL	K71-T

- Only low hydrogen coverings electrodes conforming to AWS 5.1 shall be used for MMAW.

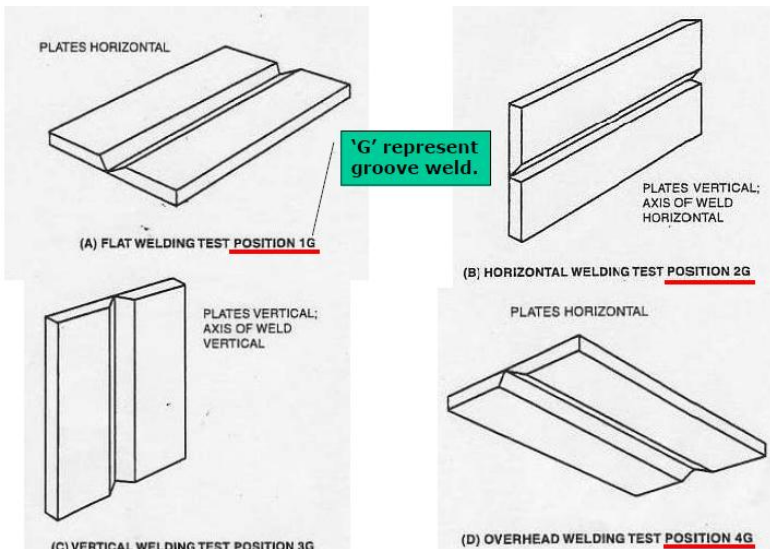

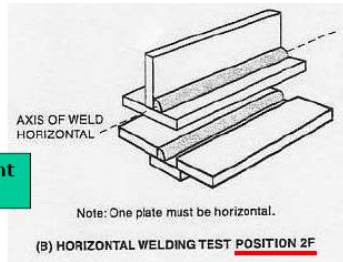
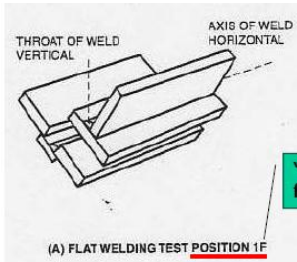

'F' represent fillet weld.

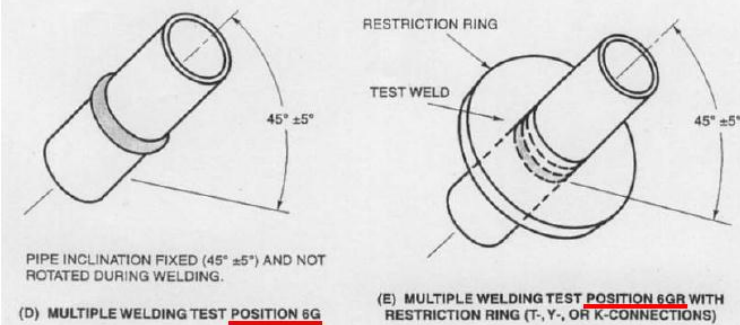
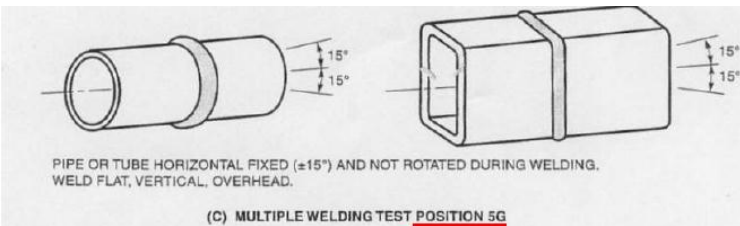
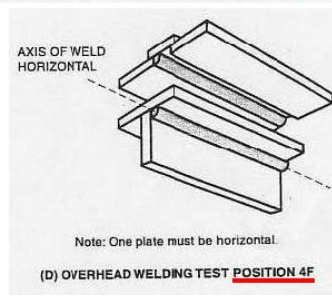
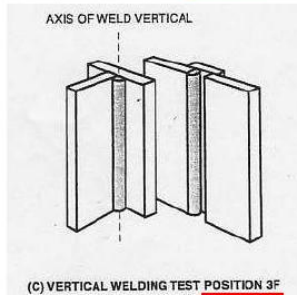

1.10.2 Welding Electrodes

- Electrodes shall be of approved type conforming to BS EN 499 and shall be kept in dry store in unbroken packages.

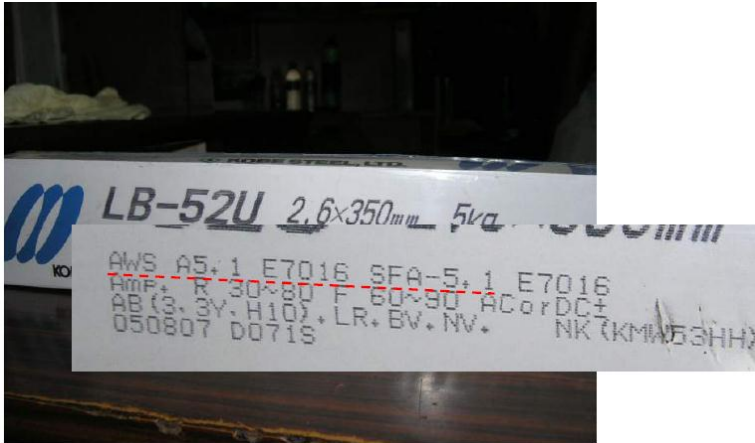

Check the classification of SMAW electrodes that printed on the box.



The number E7016 on the electrodes also printed on the box.



Check the classification of MIG welding wire on the sticker pasted on plastic holder.

1.10.3 Details of Welding Procedures

- The general procedures for shop and site welds and other details shall be in accordance to BS EN 1011-1 and BS EN 1011-2.
- For welded connections that do not permit temporary location of the member prior to final connection, the Builder shall propose adequate temporary measures to safely locate the members during welding works.
 1. Control of Welding Consumable
 - Only approved electrodes (AWS5.1/AWS5.20) are allowed in the vicinity of welding place.
 - Wet electrodes or containing moisture cannot be used.
 - Electrodes that have been removed from hermetically sealed container shall be re-baked prior to use and stored in ovens in accordance to manufacturer's recommendation.

2. Quality of Welds
 - Welds shall be uniform and correct size.
 - In the case of multilayer welding, slag, smudge and spatters on each completed bead shall be removed prior to the welding of following layer.
3. General imperfections
 - Undercut, craters, concave shape, surface crack, insufficient leg length. (Can be checked visually)
 - Incomplete fusion or penetration, cavities, slag inclusion, porosity, fine surface crack. (Detect by NDT)
4. Control of Distortion and Shrinkage
 - The size of welds shall not be unnecessarily large.
 - Jig shall be used to control distortion and shrinkage.

1.10.4 Approval and Testing of Weld

- The Builder shall carry out weld test in accordance with BS EN ISO 15614-1. The test shall be carried out on the weld at the joint of test specimen made of steel that is representative of the steel material to be used.

1.10.5 Approval of Welder

- The welder engaged in the structural steel works shall satisfy the relevant requirements of BS EN 287-1 and BS 4872-1. All welding works are to be carried out by qualified welders.

1.10.6 Measurement of Weld Sizes

- The Builder shall provide gauges necessary for measurement of weld sizes.

- Use the engage weld gauge to check the throat thickness of fillet weld by reading from the scale

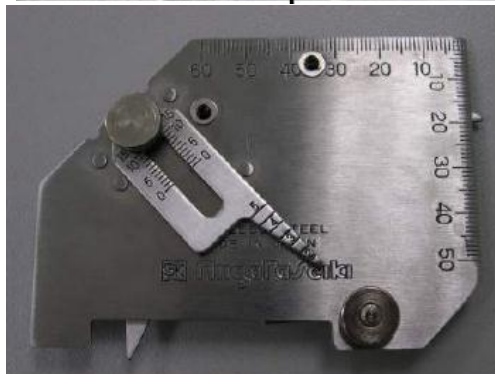

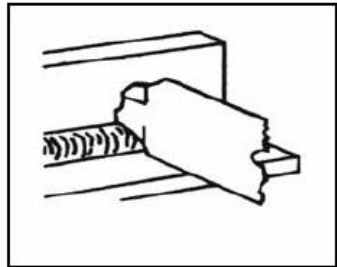
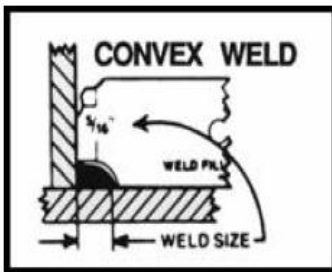
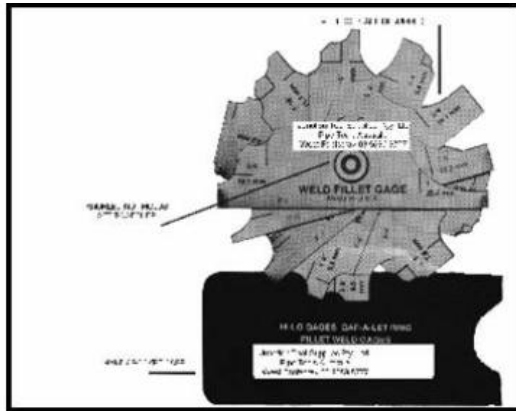

1.10.7 Testing of Weld Quality

- Weld and adjacent members shall not be painted before inspection. The following tests shall be carried out to verify the quality of weld:
 - (a) Magnetic particle flaw detection test (to BS EN ISO 9934-1);
 - (b) Penetration flaw detection test (to BS EN 571 -1);
 - (c) Ultrasonic examination (BS EN 171 4); and
 - (d) Radiographic examination (BS EN 1435).
- The tests shall be carried out by accredited testing agencies approved by the QP.

Magnetic Particles Test (MPT)

- Suitable for pointing out surface defects: such as cracks and inclusions, while it is completely useless in case of inner defects.

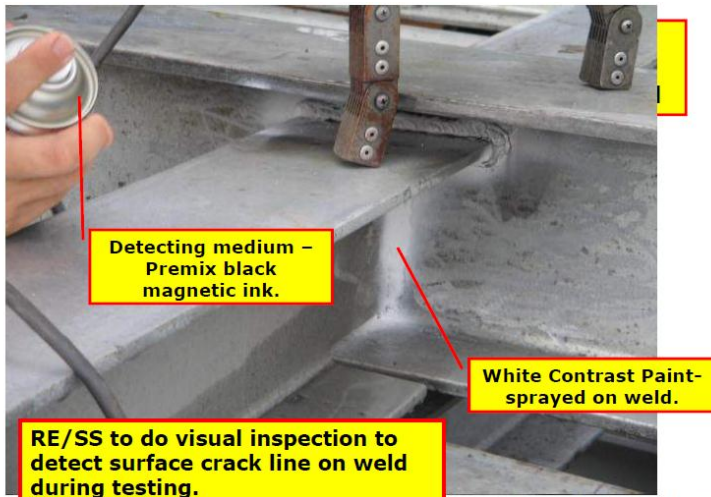

Ultrasonic Test (UT)

- Able to measure material thickness and sub-surface flaws.

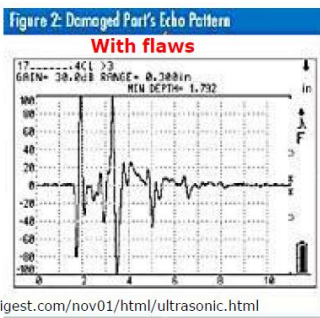
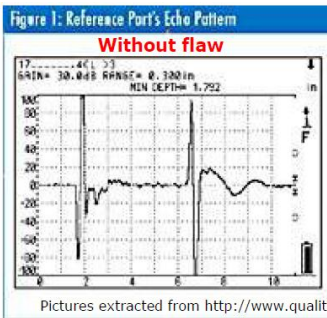

- Figure 1 shows the echo pattern from the part's unflawed area, with the two large echoes representing reflections from the front and back surfaces.
- Figure 2 depicts the pattern from an area with flaw. This echo arrives more quickly because it represents a reflection from an internal flaw.

1.10.8 Quality of Weld

- The quality of weld shall be assessed in accordance with the details specified in BS EN ISO 15614-1. Any weld with defects greater than the maximum permitted shall be liable for rejection. The visual inspection of the fusion welded joints shall be carried out in accordance with BS EN 970.

Welded joints imperfections

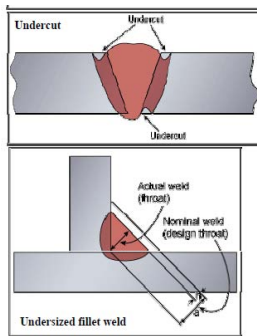

Causes of incomplete root fusion

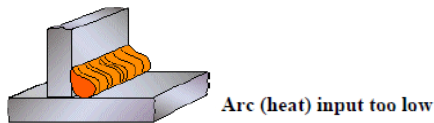
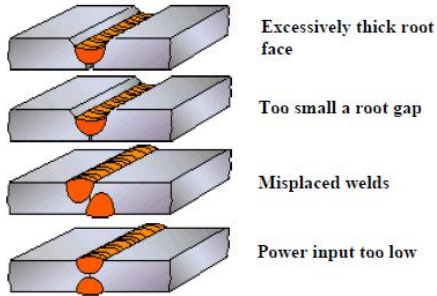

1.10.9 Frequency of Testing

- All welds shall be visually inspected in accordance with BS EN 970 before chosen for testing.
- A minimum 10% of the total number of fillet welded joint shall be chosen for testing.
- All butt welded joints shall be tested, especially for key structural members.

1.11 Bolting

1.11.1 Ordinary Bolts and Nuts

- Ordinary bolts and nuts shall comply with BS 4190. Marking of bolts shall be in accordance with BS EN ISO 898-1 and shall bear the manufacture's identification mark and property class. Marking of nuts shall be in accordance with BS EN 20898-2.
- All ordinary bolts shall be fitted with washers and nuts complying with BS 4320. Nuts shall be of at least the strength grade appropriate to the grade of bolt used.

1.11.2 High Strength Friction Grip Bolts

- The use of high strength grip bolts and associated nuts and washers complying with BS 4395-1 shall be in accordance with BS 4604.
- Other types of friction grip fasteners may also be used provided they have the mechanical properties not inferior to bolts complying with BS 4395-1 and provided that they are capable of being reliably tightened to the minimum shank tensions specified in BS 4604.

1.11.3 Methods of Tightening

- The following method shall be used for bolt tightening:
 - (a) Part turning or turn of nut;
 - (b) Torque control tightening;
 - (c) Tightening using load indicator of washer; and
 - (d) Tightening using tension control bolt.
- Tightening by other procedures shall be permitted, provided results are confirmed by tests conducted by an accredited testing agency.

1.11.4 Bolting Testing

- All bolts shall be tested in accordance with BS EN ISO 898-1 to verify the design strength specified according to the specification. A minimum of 10% of the bolts shall be tested in an accredited testing agency.
- All bolts after tightening shall be checked to ensure proper tightening particularly for every high strength friction grip bolts. A minimum of 10% of the ordinary bolts shall be checked for proper tightening.

1.11.5 Holes

- Holes for ordinary bolts shall not be more than 2 mm greater in diameter than the bolt, for bolts not exceeding 24 mm diameter and not more than 3 mm for bolts over 24 mm diameter, unless specifically required by the design.
- Holes of friction grip bolts shall be in accordance with BS 4604. Holes for bolts shall be formed by drilling and all burns shall be removed before assembly.
- Holes for fitted bolts up to and including 27 mm diameter shall not be more than 0.3 mm greater in diameter than the bolt.

1.11.6 Protection of Hollow Section

- Where a sealed hollow member is holed by a fastener or pin, provision shall be made to prevent the ingress of moisture to the interior of the member.

1.12 Riveting

- The use of rivets shall be in accordance with BS 4620.

1.13 Inspection

- The Builder shall provide adequate facilities for the inspection at any part of the steelwork during the construction.

1.14 Inspection and Testing Agency (ITA)

- For large projects with steel structures, an independent Inspection and Testing Agency (ITA) should be appointed to:
 - (a) review and accept the welding procedure specifications;
 - (b) check on the joints fit-up, size, dimensions and material quality of steel members;
 - (c) conduct inspection prior to welding, during welding and after welding;
 - (d) conduct post welding tests on the welds;
 - (e) check on bolted connections.

1.15 Load Testing

- In the event of defective materials or poor workmanship, the builder is to carry out load test to any part of the steel structure. In general, the test shall be carried out in accordance with BS 5950.

1.16 Protection against Corrosion

1.16.1 General

- The Builder shall ensure that all structural steelworks, including welds and connections shall be protected against corrosion in accordance with BS 5493 and BS 7361-1 where applicable.

1.16.2 Use of Red Lead Primer

- Painting using red lead primer shall be deemed to be the method of preventing corrosion if no other method is specified. Surface preparation shall be by means of mechanical cleaning and no blast cleaning will be required unless otherwise specified. The Builder shall apply a minimum of 2 primer coats to the steelwork, one of which shall be applied after surface preparation is completed. The second coat shall be applied only before erection.

1.16.3 Structural Steel Encased in Concrete

- Unless otherwise specified, steel surfaces to be encased in concrete shall be left unpainted and shall be cleaned and free from loose rust and scale, contamination from oil, grease and paint.

1.16.4 Other Corrosion Protection Measures

- Other methods of corrosion protection may include metallic coating, painting, bituminous coating, cathodic protection, etc. The Builder shall provide equipment for the measuring of the thickness of coating.

1.17 Surface Preparation

- All steel surfaces including welds and connections shall be thoroughly cleaned and removed of all dirt, grease and the like. All rust and loose scales shall be completely removed by mechanical cleaning, blast cleaning, wire brushing and other approved method.
- Abrasive Blasting to Standard SA 2.5 with painting. (Refer to project specifications if applicable). Painting system to be designed by approved paint supplier/specialist. Application shall follow manufacturer's instruction. Normally the structure shall be applied with primer coats in the workshop and finishing coats after erection.
- Hot Dipped Galvanizing to Standard SS 117 / BS EN ISO 1461 with Painting. (Refer to project specifications if applicable) Coating weight of Zinc for steel over 5mm thick, minimum average coating mass shall be 500g/m² and the minimum coating mass shall be 450g/m². All galvanized steel area to be painted shall first be given one coat of polyvinyl butyral etching primer and then primed with one coat of lead and chromate free primer of approved quality before erection. Painting system to be designed by approved paint specialist and application method shall follow manufacturer's instruction.
- Steel members to be encased in concrete, contact surfaces using HSFG bolts and areas to be welded shall not be painted.
- Contractor to submit blasting/painting reports (if applicable) and hot-dipped galvanizing certificates.

Abrasive blasting

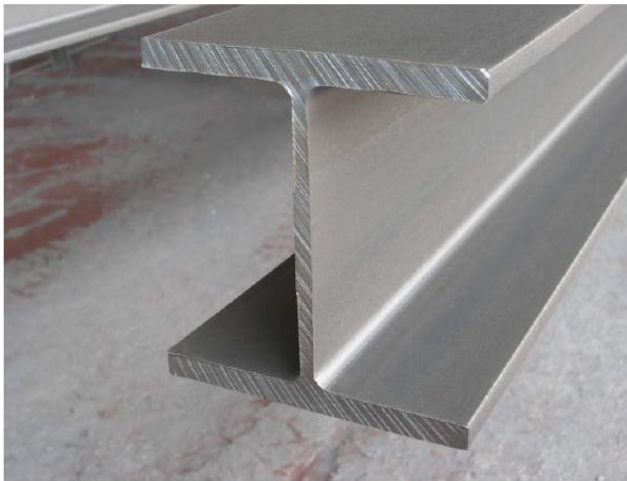

Surface condition after abrasive blasting



Application of primer immediately after abrasive blasting.

**Contractor to submit
Blasting/Painting Inspection
Report to RE if applicable.**

DOC F801 1-20
Rev'd: 15/04/2020
Page 1 of 1

SAMPLE

TTJ DESIGN & ENGINEERING PTE LTD

PROJECT BLASTING / PAINTING BAROC	REPORT NO: _____	DATE: _____
WORK LOCATION: _____	PAGE: 1	<input type="checkbox"/> CP <input type="checkbox"/>

DATE: _____	JOINT CO.: _____
COMPRESSOR: _____	TYPE OF ABRASIVE: _____
WEATHER CONDITION: _____	BLASTING STANDARD: _____
RELATIVE HUMIDITY (%): _____	POWER TOOL STANDARD: _____
STEEL TEMP. °C: _____	SURFACE PROFILE: _____
SKIN POINT °C: _____	SCHEMATIC: _____

Sl / No.	ITEMS DESCRIPTION	QTY	PAINTING SYSTEM	COAT No.	APPLICATION METHOD	AVE. WFT MICRON	AVE. DFT MICRON	BATCH No.

OTHER MENTIONED ITEMS WERE INSPECTED IN ACCORDANCE WITH APPROVED PAINT SPECIFICATION AND ACCEPTED BY THE FOLLOWING REPRESENTATIVES.

_____ APPLICATOR (DATE)	_____ PAINT. REP. (DATE)	_____ TTJ (QI / QC) (DATE)	_____ CLIENT'S REPRESENTATIVE (DATE)
----------------------------	-----------------------------	-------------------------------	---

Hot-dipped Galvanizing Certificate

Unik
UNIK ENGINEERING (PTE) LTD
SINGAPORE 911141

Serial No. 5534

Contractor to submit HD-Galvanizing Certificate issued by Galvanizer to RE.

CERTIFICATE

To: **NU OHU ENGINEERING & TRANSPORT LTD**
PMA BUILDING P.O. BOX 0810
SINGAPORE 911141

To ensure correct specification and coating thickness.

BS EN ISO 1461 : 1999 SPECIFICATION

This is to certify that the following Galvanized to **having an average coating thickness of**

610 GM PER METRE SQUARE

TO ENSURE CORRECT STRUCTURE.

REQUIREMENTS:

BS EN ISO 1461 : 1999 SPECIFIED having an average coating thickness of 610 GM PER METRE SQUARE.	PIT: SILOSO BEACH WATER SHOW HOLLOW FRAME (TOWER 4 TRELLIS SUPPORT FRAME) 4 FRAMES HOLLOW FRAME (TOWER 1 TRELLIS SUPPORT FRAME) 4 FRAMES HOLLOW FRAME (TOWER 3 TRELLIS SUPPORT FRAME) 4 FRAMES HOLLOW FRAME (TOWER 2 TRELLIS SUPPORT FRAME) 4 FRAMES
---	---

Signed by all relevant parties.

Head Production Section
091 20000
Date

Project Head
091 233006
Date

Version 1.0 (Released 31st Mar 07)

Stripping Test

Accredited Laboratory

SETSCO SERVICES PTE LTD
18 Farrer Green Crescent
Singapore 12047
Tel: 26100011/12
Fax: 26100011/12
Website: www.setsco.com.sg
Business Hours: 0900AM - 0500PM
Your Part: 11/01/07/01/07/01/07

OUR Ref: CH-12457BY

TEST REPORT

Subject: Determination of galvanized coating mass on steel articles submitted by Ye Go Engineering & Trading Pte Ltd on 02/12/2006 and tested on 02/12/2006.

Tested For: Farfetch Commodities Pte Ltd
Development Project: Division (P. Mpp)
1st Lt. Mr. Philip Munn
Date: 12/02/07

15 DEC 2006
RECEIVED

Date: 09/12/2006
Page 1 of 1

To ensure correct specification.

Specification : SS 117 : 1975

Compare results with minimum requirements and ensure test result pass

Sample Reference	Mass of zinc coating per unit of steel surface (g/m ²)		SS 117 : 1975 Minimum Average Requirements (g/m ²)
	Average	Minimum Individual	
Calibrated Steel Section	1871	1449	Average : 500 Individual : 450

ELIAS BIN FAKRI
TECHNICAL OFFICER

JOHNNEE SUI
SENIOR ENGINEER

PHYSICAL & CHEMICAL TECHNOLOGY DIVISION

11 Damrau Construction Limited (Singapore Branch)
19 International Business Park, #05-05
Ayer Rajah, Tower B
Singapore 629242

All relevant parties signed

1.18 Fire Protection

- All steel sections shall be protected against fire to comply with the requirements of the Code of Practice for Fire Precautions in Buildings for the respective fire ratings.
- Where spray-on fire proofing materials, or fire resistant boards, or intumescent coatings are used to protect the steel against fire, the product used shall be listed in the Singapore Civil Defence Force (SCDF) approved Product Listing Scheme (PLS).
- The method of application or installation and the thickness of materials, boards or coatings shall be checked to ensure that they are in accordance to those specified for that particular product in the PLS.
- Where the product is not listed in the PLS, there shall be a letter of acceptance for that product from the SCDF on its use in the fire safety works being supervised, and checks shall be carried out to ensure that the conditions spelt out in the letter of acceptance are complied with and that the product has been installed or applied in accordance to the prototype tests given in the test report submitted to SCDF to obtain the letter of acceptance.
- Where the protection for the steel sections is constructed in accordance with one of the specifications set out in the Code of Practice for Fire Precautions in Buildings, checks shall be carried out to ensure that the protection is constructed as specified in the code.

Checklist1

Steel work inspection

(see 7.8.1)

Project: _____

Location: _____

(A) Inspection of steel section before erection

Part to be inspected	Dimensions (section size)	Corrosion protection	Miscellaneous	Temporary work/ bracing

Submitted by: _____ Name & signature of Builder's Representative
 Checked by: _____ Name & signature of Site Supervisor
 Approved by: _____ Name & signature of Project PE

Date: _____ Date: _____ Date: _____

(B) Inspection of steel section after erection

Location of part to be inspected	Item to be checked (Tick if acceptable)				
	Alignment	Level	Connection detail		Fire-protection (Type / thickness)
			Bolt	Weld	

Submitted by: _____ Name & signature of Builder's Representative
 Checked by: _____ Name & signature of Site Supervisor
 Approved by: _____ Name & signature of Project PE

Date: _____ Date: _____ Date: _____

APPENDICES

Accuracy of fabrication

7.1 PERMITTED DEVIATIONS

Permitted deviations in cross section, length, straightness, flatness, cutting, holing and position of fittings shall be as specified in 7.2 to 7.5 below.

7.2 PERMITTED DEVIATIONS FOR ROLLED COMPONENTS AFTER FABRICATION (Δ)
(including structural hollow sections)

7.2.1 Cross section after fabrication

In accordance with the appropriate tolerances standard given in Table 2.1

7.2.2 Squareness of ends not prepared for bearing

Note: See also 4.3.3

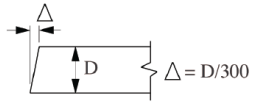

Plan or elevation of end

7.2.3 Squareness of ends prepared for bearing

Prepare ends with respect to the longitudinal axis of the member.

Note: See also 4.3.3

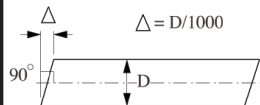

Plan or elevation

7.2.4 Straightness on both axes

Generally $\Delta = L/1000$ or 3mm whichever is greater.

For components fabricated from structural hollow sections $\Delta = L/500$ or 3mm whichever is greater.

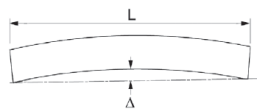

7.2.5 Length

Length after cutting, measured on the centre line of the section or on the corner of angles.

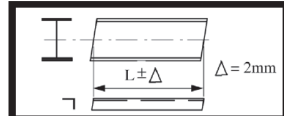

7.2.6 Curved or cambered

Deviation from intended curve or camber at mid-length of curved portion when measured with web horizontal.

Deviation = $L/1000$ or 6mm whichever is greater.

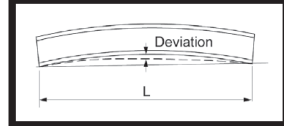

7.3 PERMITTED DEVIATIONS FOR ELEMENTS OF FABRICATED COMPONENTS (Δ)

7.3.1 Position of fittings

The deviation from the intended position relative to the setting-out point on the primary member shall not exceed Δ .

Fittings and attachments whose location is critical to the force path in the structure:
 $\Delta = 3\text{mm}$

Other fittings and attachments: $\Delta = 5\text{mm}$

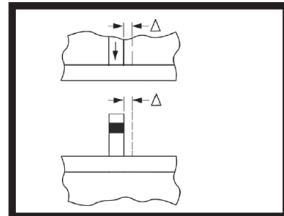

7.3.2 Alignment of fittings

Angular deviation \emptyset relative to intended local orientation.

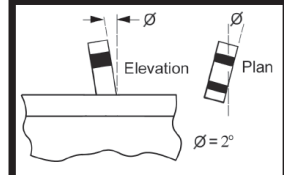

7.3.3 Position of holes

The deviation from the intended position of an isolated hole, also within a group of holes, the relative position to each other shall not exceed Δ .

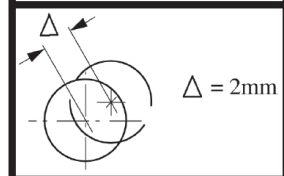

7.3.4 Punched holes

The distortion caused by a punched hole shall not exceed Δ .

$\Delta = D/10$ or 1mm whichever is greater.

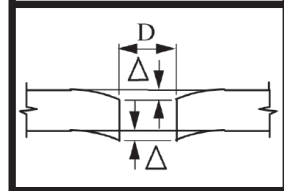

7.3.5 Sheared or cropped edges of plates or angles

The deviation from a 90° edge shall not exceed Δ

$\Delta = t/10$ up to a maximum of 3mm.

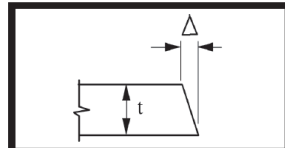

7.3.6 Flatness

Where full contact bearing is specified, the flatness shall be such that when measured against a straight edge not exceeding one metre long, which is laid against the full bearing surface in any direction, the gap does not exceed Δ

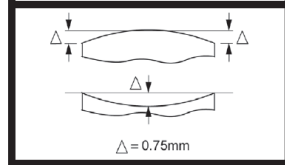

7.4 PERMITTED DEVIATIONS FOR PLATE GIRDER SECTIONS (Δ)

7.4.1 Depth

Depth on centre line.

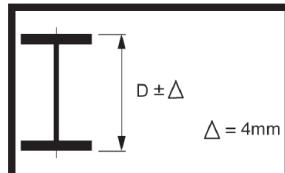

7.4.2 Flange width

Width of B_w or B_n .

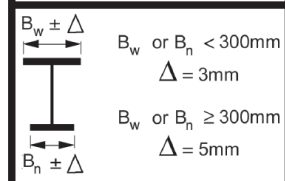

7.4.3 Squareness of section

Out of squareness of flanges.

$\Delta = B/100$ or 3mm whichever is greater.

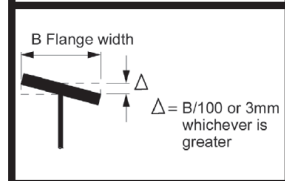

7.4.4 Web eccentricity

Position of web from edge of flange.

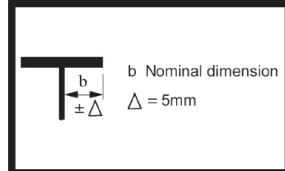

7.4.5 Flanges
Out of flatness.

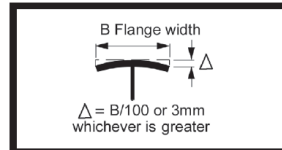

7.4.6 Top flange of crane girder
Out of flatness where the rail seats.

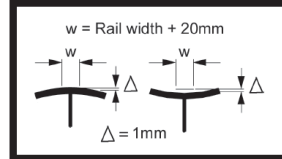

7.4.7 Length
Length on centre line.

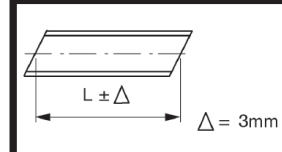

7.4.8 Flange straightness
Straightness of individual flanges.

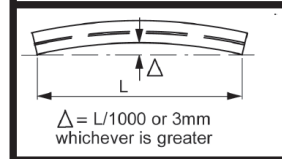

7.4.9 Curved or cambered
Deviation from intended curve or camber at mid-length of curved portion when measured with the web horizontal. Deviation = $L/1000$ or 6mm whichever is greater.

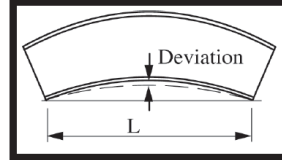

7.4.10 Web distortion
Distortion on web depth or gauge length. $\Delta = d/150$ or 3mm whichever is greater.

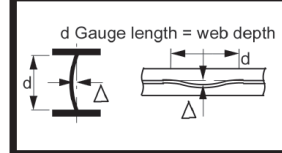

7.4.11 Cross section at bearings
Squareness of flanges to web. $\Delta = D/300$ or 3mm whichever is greater.

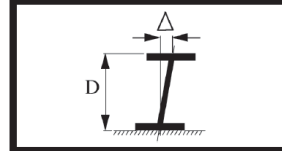

7.4.12 Web stiffeners

Straightness of stiffener out of plane with web after welding.

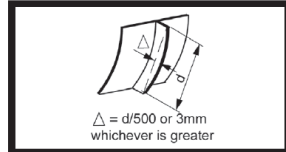

7.4.13 Web stiffeners

Straightness of stiffener in plane with web after welding.

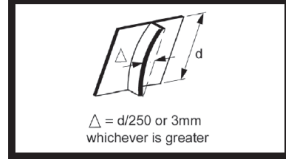

7.5 PERMITTED DEVIATIONS FOR BOX SECTIONS (Δ)

7.5.1 Plate widths

Width of B_f or B_w .

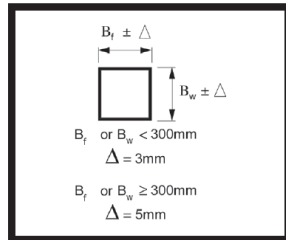

7.5.2 Squareness

Squareness at diaphragm positions.

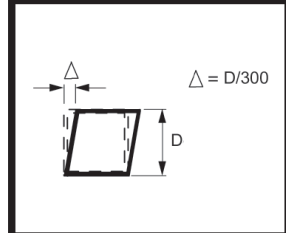

7.5.3 Plate distortion

Distortion on width or gauge length.

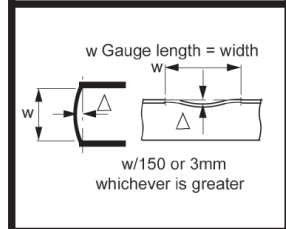

7.5.4 Web or flange straightness

Straightness of individual web or flanges.

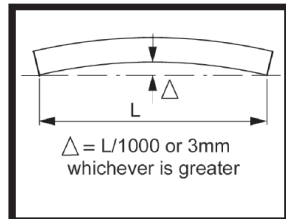

7.5.5 Web stiffeners

Straightness in plane with plate after welding.

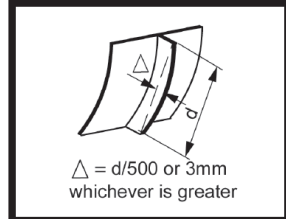

7.5.6 Web stiffeners

Straightness out of plane to plate after welding.

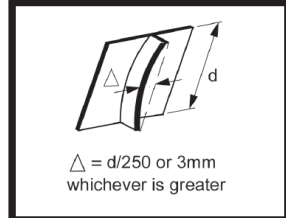

7.5.7 Length

Length on centre line.

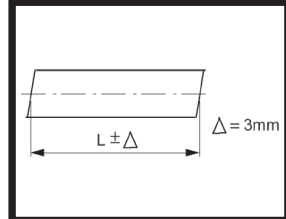

7.5.8 Curved or cambered

Deviation from intended curve or camber at mid-length of curved portion when measured with the uncambered side horizontal.

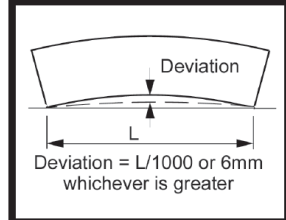

Accuracy of erection

9.1 PERMITTED DEVIATIONS FOR FOUNDATIONS, WALLS AND FOUNDATION BOLTS (Δ)

Note: The permitted deviations in 9.1.1 to 9.1.5 are consistent with the National Structural Concrete Specification.

9.1.1 Foundation level

Deviation from specified level.

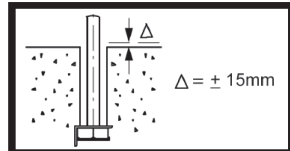

9.1.2 Vertical wall

Deviation from specified position at steelwork support point.

$\Delta = \pm 15\text{mm}$ up to 4m height

$\Delta = \pm 20\text{mm}$ above 4m plus 1mm for every metre above 8m height to $\pm 50\text{mm}$ maximum

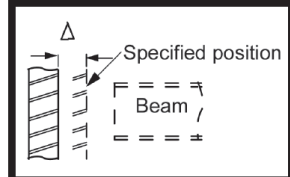

9.1.3 Pre-set foundation bolt or bolt groups if prepared for adjustment

Deviation from specified position.

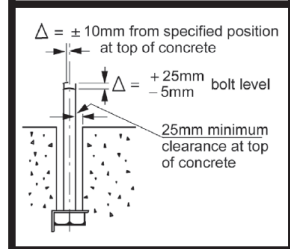

9.1.4 Pre-set foundation bolt or bolt groups if not prepared for adjustment

Deviation from specified position.

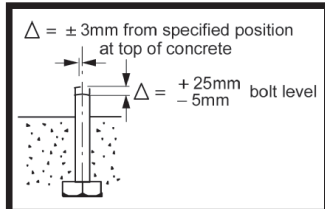

9.1.5 Pre-set wall bolt or bolt groups if not prepared for adjustment

Deviation from specified position.

Note: This is measured locally relative to the achieved verticality of the wall as specified in 9.1.2.

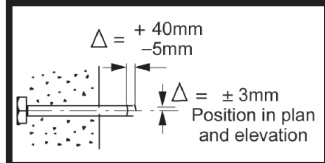

9.1.6 Embedded cast-in fixing plates

Deviation of centre lines from specified positions.

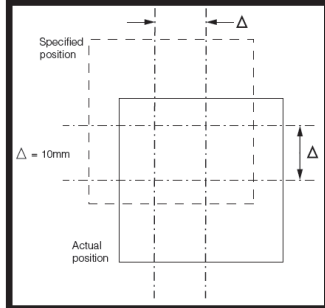

9.6 PERMITTED DEVIATIONS OF ERECTED COMPONENTS (Δ)

9.6.1 Position of columns at base

Deviation of section centre line from the specified position.

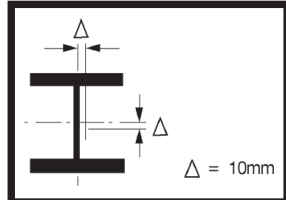

9.6.2 Level of columns at base

Deviation of the top of the base plate from the specified level.

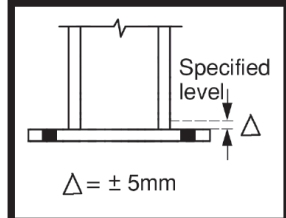

9.6.3 Single storey columns plumb

Deviation of top relative to base, excluding portal frame columns, on main axes.

Note: See clause 1.2A(xvii) and 3.4.4(iii) regarding pre-setting portal frames.

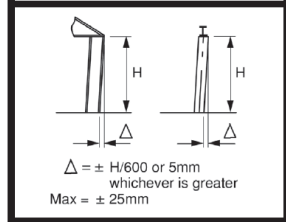

9.6.4 Multi-storey columns plumb

Deviation in each storey and maximum deviation relative to base for up to 10 storeys.

Note: Permitted deviations for columns over 10 storeys to be agreed with the Engineer.

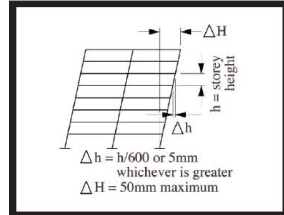

9.6.5 Gap between bearing surfaces

Note: See also clauses 4.3.3, 6.2.1 and 7.2.3

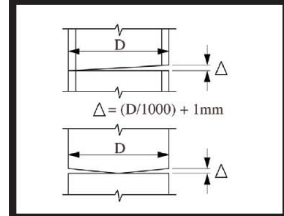

9.6.6 Eccentricity at column splice

Non-intended eccentricity about either axis.

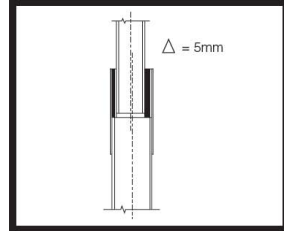

9.6.7 Alignment at column splice

Straightness of a spliced column between adjacent storey levels.

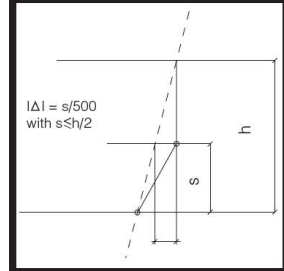

9.6.8 Alignment of adjacent perimeter columns

Deviation relative to next column on a line parallel to the grid line when measured at base or splice level.

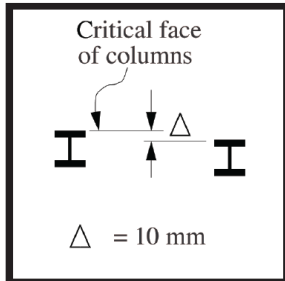

9.6.9 Beam level

Deviation from specified level at supporting column.

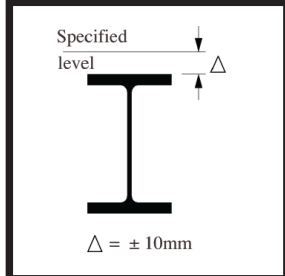

9.6.10 Level at each end of same beam

Relative deviation in level at ends.

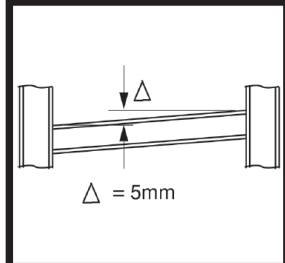

9.6.11 Level of adjacent beams within a distance of 5 metres

Deviation from relative horizontal levels (measured on centre line of top flange).

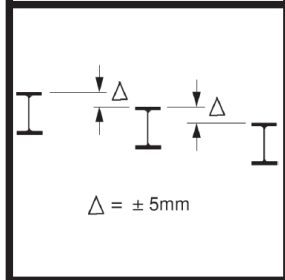

9.6.12 Beam alignment

Horizontal deviation relative to an adjacent beam above and below.

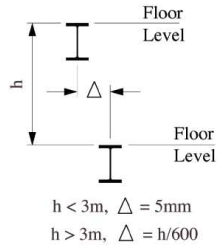

9.6.13 Crane gantry columns plumb

Deviation of cap relative to base.

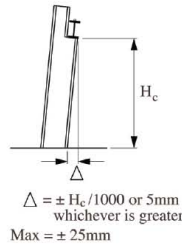

9.6.14 Crane gantries gauge of rail tracks

Deviation from nominal gauge.

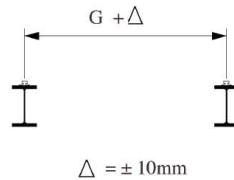

9.6.15 Eccentricity of rail relative to web

$\Delta = 5\text{mm}$ for $t_w < 10\text{mm}$

$\Delta = t_w/2$ for $t_w > 10\text{mm}$

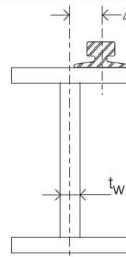

9.6.16 Rail surface at joints in gantry crane rails

Deviation in level at rail joint.

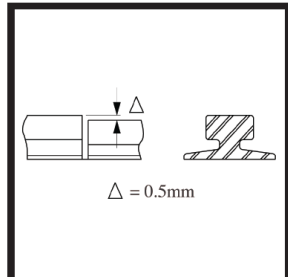

9.6.17 Rail edge at joints in gantry crane rails

Deviation in line at rail joint.

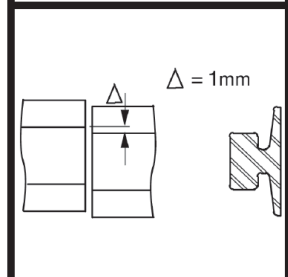

9.6.18 Profiled steel floor decking

Deviation of dimension between decking edge trim prior to concrete placement and perimeter beam.

Note: The deviation (as shown) between actual beam centre line and intended beam centre line relative to local grid arises from other permitted tolerances (e.g. 9.6.4).

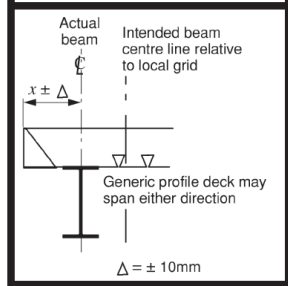

Published by:

The Institution of Engineers, Singapore

70 Bukit Tinggi Road

Singapore 289758

All rights reserved.

©2011 IES-ACES Joint Accreditation Committee

S\$20 nett